

## 1 1/2 TAPAS&amp;SUSHI

## GRANTAPAS 3 GN 1/1 2

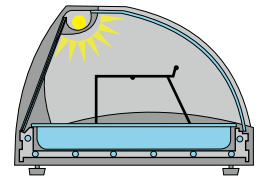
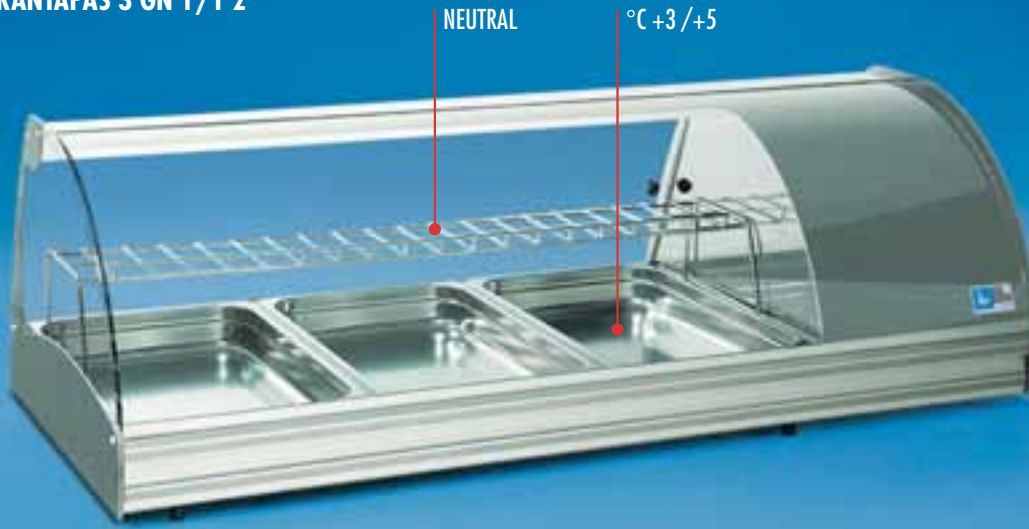

GRANTAPAS 3 GN 1/1 2

## TAPAS 6 GN 2

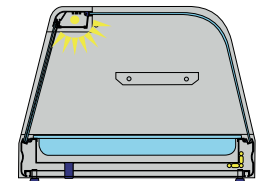

\* TAPAS GN 2

\*  
Tapas GN 2: vetro curvo non apribile.  
Tapas GN 2: not opening curved glass.  
Tapas GN 2: verre bombée non ouvrant.  
Tapas GN2: nicht aufklappbares  
gewölbtes Glas. /  
Tapas GN2: cristal curvado no abatible.

Con luce protetta  
With shielded light  
Avec lumière protégée  
Mit geschütztem Licht  
Con luz protegida

Porte scorrevoli  
Sliding doors /Portes coulissantes  
Schiebetüre  
Puertas corredizas

Struttura in acciaio inox  
Stainless steel structure  
Structure en acier inox  
Konstruktion aus rostfreiem Stahl  
Estructura en acero inox

TAPAS GN: N° BACINELLE GN H. 40 mm / NR. OF BASINS GN H. 40 mm / N. DES BACS H. 40 mm / SCHALENNUMMER GN H. 40 mm / N. DE CUBETERAS H. 40 mm  
GRANTAPAS GN: N° BACINELLE GN H. 65 mm / NR. OF BASINS GN H. 65 mm / N. DES BACS H. 65 mm / SCHALENNUMMER GN H. 65 mm / N. DE CUBETERAS H. 40 mm

	GRANTAPAS 3 GN 1/1 - 2 GRANTAPAS 3 GN 1/1 - 2 SPLIT	TAPAS 4 GN 2	TAPAS 6 GN 2	TAPAS 8 GN 2
GN 1/3	9	4	6	8
GN 1/1	3	—	—	—

## GRANTAPAS 3 GN 1/1 - 2

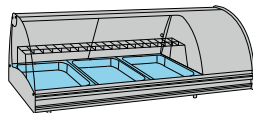

(LxPxH)  
1320x600x470

## GRANTAPAS 3 GN 1/1 - 2 SPLIT

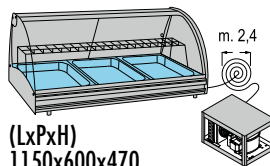





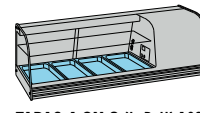



(LxPxH)  
1150x600x470

## TAPAS GN 2



TAPAS 4 GN 2 (LxPxH) 1085x396x340  
TAPAS 6 GN 2 (LxPxH) 1437x396x340  
TAPAS 8 GN 2 (LxPxH) 1789x396x340

Modello Model Modèle Modell Modelo	Potenza Power Puisissance Gesamtleistung Potencia	Tensione Tension Tension Spannung Tension	Temperatura Temperature Temperature Temperatur Temperatura	Refrigerazione Refrigeration Refrigeration Kühlung Refrigeracion	Sbrinamento Defrosting Degivrage Enteisung Desescarche	Gas refrigerante Cooling gas Gaz réfrigérant Kühlgas Gas refrigerante	Peso netto Net weight Poids net Nettogewicht Peso neto
 <b>GRANTAPAS 3 GN 1/1 - 2</b>	Watt 230	230v/1/50Hz	°C +3/+5			R 134a	Kg 70
<b>TAPAS 4 GN 2</b>	Watt 184	230v/1/50Hz	°C +3/+5			R 134a	Kg 35
<b>TAPAS 6 GN 2</b>	Watt 207	230v/1/50Hz	°C +3/+5			R 134a	Kg 40
<b>TAPAS 8 GN 2</b>	Watt 230	230v/1/50Hz	°C +3/+5			R 404a	Kg 45

## 1 1/2 TAPAS&amp;SUSHI

200

*Vetrine calde e refrigerate da appoggio con vetro curvo / Hot and refrigerated bearing display cabinets with bent glass /  
Vitrines chaudes et réfrigérantes d'appui avec vitre bombée / Warm und Kühlvitrinen zum Auflegen, mit gebogenem Glas /  
Vitrinas refrigeradas y calientes de apoyo con vidrio curvo*

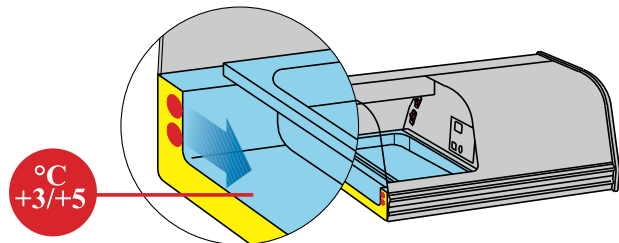

## TAPAS

- Mediante l'applicazione COLD SYSTEM si rende uniforme la diffusione del freddo su tutta la superficie delle vaschette (con acqua = bagno maria freddo o senz'acqua = freddo secco).
- The COLD SYSTEM application allows an even cold diffusion on the whole surface of the tanks (with water = cold water bath or without water = dry cold).
- Par l'intermédiaire de l'application COLD SYSTEM, il est possible d'uniformiser la diffusion du froid sur toute la surface des bacs (avec eau = bain marie froid ou sans eau = froid sec).
- Durch die Anwendung vom COLD SYSTEM verteilt sich die Kälte gleichmäßig auf die ganze Schalenfläche (mit Wasser = kühles Bain-marie bzw. ohne Wasser = trockene Kälte).
- La difusión del frío es uniforme sobre toda la superficie de las cubetas por medio del sistema COLD SYSTEM (con agua = baño maria frío o sin agua = frío seco).

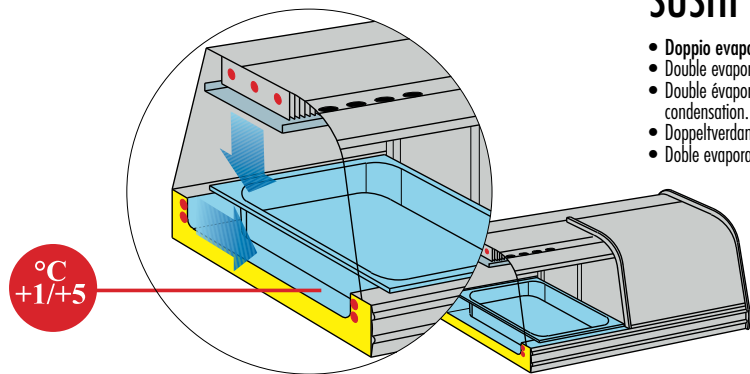

## SUSHI

- Doppio evaporatore: l'evaporatore superiore è dotato di bacinella raccolta condensa.
- Double evaporator: the upper evaporator is supplied with condensate basin.
- Double évaporateur : l'évaporateur supérieur est équipé d'une bassine pour la récupération de l'eau de condensation.
- Doppelverdampfer: der obere Verdampfer ist mit Kondenswassersammelbehälter ausgestattet.
- Doble evaporador: el evaporador superior es equipado con bandeja de recolección agua de condensación.

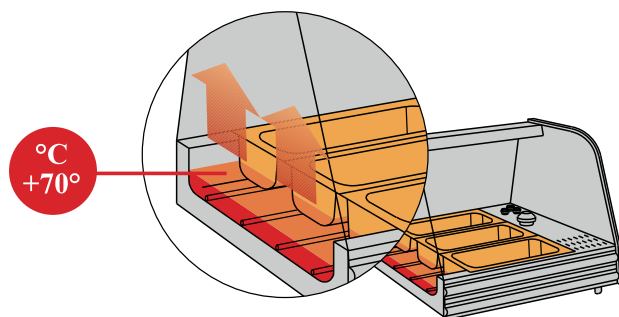

## TAPAS BAIN-MARIE

LE BACINELLE NON SONO COMPRESSE NEL PREZZO / BASINS ARE NOT INCLUDED IN THE PRICE / LES BASSINES NE SONT PAS COMPRISES DANS LE PRIX / DIE SCHALEN SIND IM PREIS NICHT INBEGRIFFEN / EL PRECIO NO COMPRENDE LAS BANDEJAS



Colore argento / Silver colour / Couleur argent / Silber-Farbe / Color plata



Colore oro / Gold colour / Couleur or / Gold-Farbe / Color oro



Colore bronzo / Bronze colour / Couleur bronze / Bronze-Farbe / Color bronze



Colore nero / Black / Couleur noir / Schwarzfarbe / Color negro

# Legenda Symbols



**Modello**  
Model  
Modèle  
Modell  
Modelo



**Umidità**  
Humidity  
Hygrométrie  
Luftfeuchtigkeit  
Humedad



**Potenza compressore**  
Compressor power  
Puissance compresseur  
Leistung des Kompressors  
Potencia compresor



**Capacità**  
Capacity  
Capacité  
Kapazität  
Capacidad

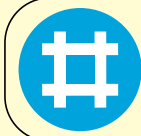

**Ripiani a griglia**  
Grating shelves  
Etagères à grille  
Gitter-Fächer  
Repisas enrejadas

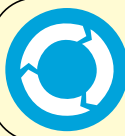

**Ripiani rotanti in vetro**  
Rotating glass shelves  
Etagères tournantes en verre  
Drehbare Glasfächer  
Repisas giratorias de vidrio



**Ripiani in cristallo**  
Crystal plates  
Tablettes en cristal  
Glasteller  
Estantes de cristal



**Temperatura**  
Temperature  
Température  
Temperatur  
Temperatura

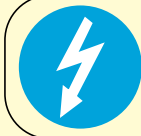

**Voltaggio di serie**  
Standard voltage  
Voltage standard  
Serienmäßige Spannung  
Voltaje en serie



**Sbrinamento manuale**  
Manual defrosting  
Dégivrage manuel  
Manuelles Abtauen  
Descongelación manual



**Sbrinamento automatico**  
Automatic defrosting  
Dégivrage automatique  
Automatisches Abtauen  
Descongelación automática



**Refrigerazione**  
Refrigeration  
Réfrigération  
Kühlung  
Refrigeración



**Refrigerazione statica**  
Static refrigeration  
Réfrigération statique  
Statische Kühlung  
Refrigeración estática



**Refrigerazione ventilata**  
Ventilated refrigeration  
Réfrigération ventilée  
Belüftete Kühlung  
Refrigeración ventilada



**Refrigerazione agitata**  
Fan assisted refrigeration  
Réfrigération troublée  
Geschüttelte Kühlung  
Refrigeración estática con pseudo-ventilador



**Gas refrigerante**  
Cooling gas  
Gaz réfrigérant  
Kühlgas  
Gas refrigerante



**Potenze resistenze Bain-Marie**  
Bain-Marie heating elements power  
Puissance des résistances Bain-Marie  
Leistung der wasserbadheizkörper  
Potencia resistencias Baño María



**Peso netto**  
Net weight  
Poids net  
Nettogewicht  
Peso neto



**Bacinelle**  
Trays  
Cuvettes  
Schalen  
Bandejas

EUROLINE  
VINO  
BIRRA  
BAR  
MERCATI SPECIALI  
LABORATORI PASTICCERIA  
RISTORAZIONE  
FAST FOOD  
PIZZERIA  
CUCINA  
ESPOSIZIONE  
SUPERMERCATI  
HYPERMARKET