

TAPAS 6 GN



Con luce protetta
With shielded light
Avec lumière protégée
Mit geschütztem Licht
Con luz protegida

Porte scorrevoli
Sliding doors /Portes coulissantes
Schiebetüre
Puertas corredizas

Struttura in acciaio inox
Stainless steel structure
Structure en acier inox
Konstruktion aus rostfreiem Stahl
Estructura en acero inox

Tappas: vetro curvo apribile di serie.
Migliora la manutenzione interna della vetrina.

Tappas: production opening curved glass.
It makes the display cabinet internal maintenance easier.

Tappas: verre bombé ouvrant de série.
Il améliore l'entretien intérieur de la vitrine.

Tappas: serienmäßiges aufklappbares gewölbtes Glas.
Es erleichtert die Innenpflege der Vitrine.

Tappas: cristal curvado abrible corriente.
Mejora el mantenimiento interno de la vitrina.



TAPAS 6 GN SG / TAPAS 6 GN SPLIT



TAPAS PI

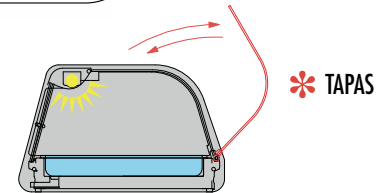

***** TAPAS

N° BACINELLE GN 1/3 H. 40 mm / NR. OF BASINS GN 1/3 H. 40 mm
N. DES BACS GN 1/3 H. 40 mm / SCHALENNUMMER GN 1/3 H. 40 mm
N. DE CUBETERAS GN 1/3 H. 40 mm

	TAPAS 4 GN	TAPAS 6 GN TAPAS 6 GN - SG TAPAS 6 GN - SPLIT	TAPAS 8 GN TAPAS 8 GN - SG TAPAS 8 GN - SPLIT	TAPAS 10 GN TAPAS 10 GN - SG TAPAS 10 GN - SPLIT
N°	4	6	8	10

TAPAS GN

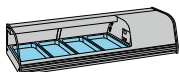

TAPAS 4 GN (LxPxH) 1085x396x245
TAPAS 6 GN (LxPxH) 1437x396x245
TAPAS 8 GN (LxPxH) 1789x396x245
TAPAS 10 GN (LxPxH) 2141x396x245

TAPAS GN - SG

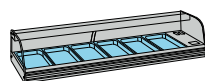

TAPAS 6 GN - SG (LxPxH) 1150x396x245
TAPAS 8 GN - SG (LxPxH) 1490x396x245
TAPAS 10 GN - SG (LxPxH) 1910x396x245

TAPAS GN - SPLIT

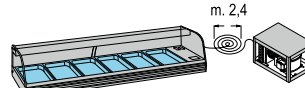

TAPAS 6 GN - SPLIT (LxPxH) 1150x396x245
TAPAS 8 GN - SPLIT (LxPxH) 1490x396x245
TAPAS 10 GN - SPLIT (LxPxH) 1910x396x245

TAPAS PI

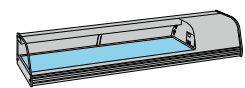

TAPAS 6 PI (LxPxH) 1437x396x245
TAPAS 8 PI (LxPxH) 1789x396x245
TAPAS 10 PI (LxPxH) 2141x396x245

Modello Model Modèle Modell Modelo	Potenza Power Puissance Gesamtleistung Potencia	Tensione Tension Tension Spannung Tension	Temperatura Temperature Temperature Temperatur Temperatura	Refrigerazione Refrigeration Refrigeration Kuehlung Refrigeracion	Sbrinamento Defrosting Degivrage Enteisung Desescarche	Gas refrigerante Cooling gas Gaz réfrigérant Kühlgas Gas refrigerante	Peso netto Net weight Poids net Nettogewicht Peso neto
TAPAS 4 GN	Watt 184	230v/1/50Hz	°C +3/+5			R 134a	Kg 30
TAPAS 6 GN	Watt 207	230v/1/50Hz	°C +3/+5			R 134a	Kg 34
TAPAS 8 GN	Watt 230	230v/1/50Hz	°C +3/+5			R 404a	Kg 38
TAPAS 10 GN	Watt 230	230v/1/50Hz	°C +3/+5			R 404a	Kg 45
TAPAS 6 PI	Watt 207	230v/1/50Hz	°C +3/+5			R 134a	Kg 34
TAPAS 8 PI	Watt 230	230v/1/50Hz	°C +3/+5			R 404a	Kg 38
TAPAS 10 PI	Watt 230	230v/1/50Hz	°C +3/+5			R 404a	Kg 45

Dati di collaudo - Test details - Détails d'essai - Prüfungsergebnisse - Datos de ensayo - MAX = (30°C - % U.R. 55)

1 1/2 TAPAS&SUSHI

200

*Vitrine calde e refrigerate da appoggio con vetro curvo / Hot and refrigerated bearing display cabinets with bent glass /
Vitrines chaudes et réfrigérantes d'appui avec vitre bombée / Warm und Kühlvitrinen zum Auflegen, mit gebogenem Glas /
Vitrinas refrigeradas y calientes de apoyo con vidrio curvo*

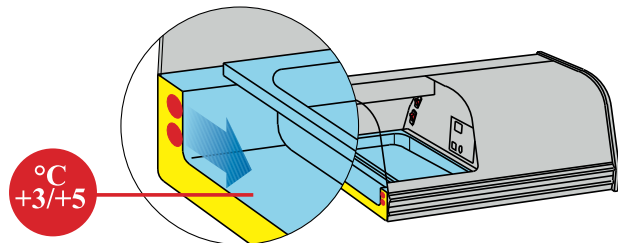

TAPAS

- Mediante l'applicazione COLD SYSTEM si rende uniforme la diffusione del freddo su tutta la superficie delle vaschette (con acqua = bagno maria freddo o senz'acqua = freddo secco).
- The COLD SYSTEM application allows an even cold diffusion on the whole surface of the tanks (with water = cold water bath or without water = dry cold).
- Par l'intermédiaire de l'application COLD SYSTEM, il est possible d'uniformiser la diffusion du froid sur toute la surface des bacs (avec eau = bain marie froid ou sans eau = froid sec).
- Durch die Anwendung vom COLD SYSTEM verteilt sich die Kälte gleichmäßig auf die ganze Schalenfläche (mit Wasser = kühles Bain-marie bzw. ohne Wasser = trockene Kälte).
- La difusión del frío es uniforme sobre toda la superficie de las cubetas por medio del sistema COLD SYSTEM (con agua = baño maria frío o sin agua = frío seco).

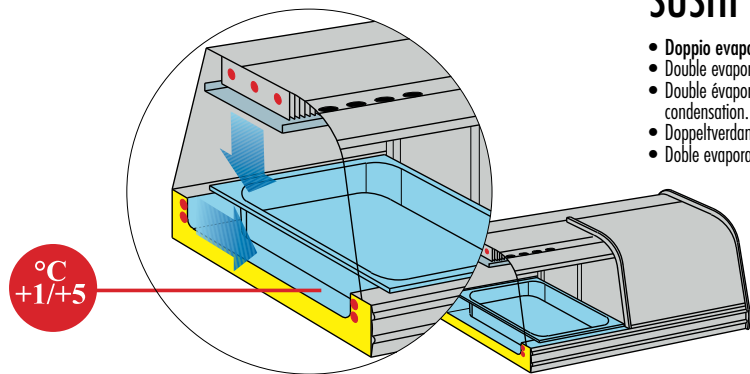

SUSHI

- Doppio evaporatore: l'evaporatore superiore è dotato di bacinella raccolta condensa.
- Double evaporator: the upper evaporator is supplied with condensate basin.
- Double évaporateur : l'évaporateur supérieur est équipé d'une bassine pour la récupération de l'eau de condensation.
- Doppelverdampfer: der obere Verdampfer ist mit Kondenswassersammelbehälter ausgestattet.
- Doble evaporador: el evaporador superior es equipado con bandeja de recolección agua de condensación.

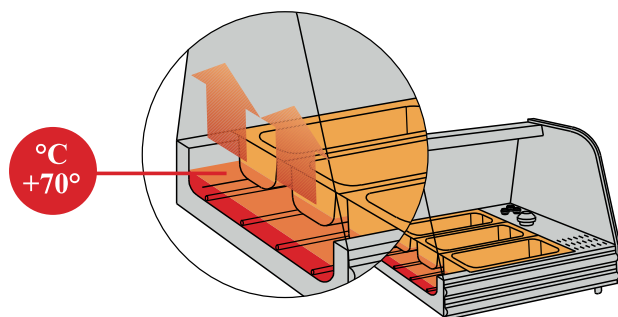

TAPAS BAIN-MARIE

LE BACINELLE NON SONO COMPRESSE NEL PREZZO / BASINS ARE NOT INCLUDED IN THE PRICE / LES BASSINES NE SONT PAS COMPRISES DANS LE PRIX / DIE SCHALEN SIND IM PREIS NICHT INBEGRIFFEN / EL PRECIO NO COMPRENDE LAS BANDEJAS



Colore argento / Silver colour / Couleur argent / Silber-Farbe / Color plata



Colore oro / Gold colour / Couleur or / Gold-Farbe / Color oro



Colore bronzo / Bronze colour / Couleur bronze / Bronze-Farbe / Color bronze



Colore nero / Black / Couleur noir / Schwarzfarbe / Color negro

Legenda Symbols



Modello
Model
Modèle
Modell
Modelo



Umidità
Humidity
Hygrométrie
Luftfeuchtigkeit
Humedad



Potenza compressore
Compressor power
Puissance compresseur
Leistung des Kompressors
Potencia compresor



Capacità
Capacity
Capacité
Kapazität
Capacidad

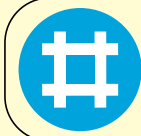

Ripiani a griglia
Grating shelves
Etagères à grille
Gitter-Fächer
Repisas enrejadas

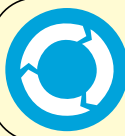

Ripiani rotanti in vetro
Rotating glass shelves
Etagères tournantes en verre
Drehbare Glasfächer
Repisas giratorias de vidrio



Ripiani in cristallo
Crystal plates
Tablettes en cristal
Glasteller
Estantes de cristal



Temperatura
Temperature
Température
Temperatur
Temperatura

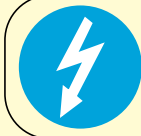

Voltaggio di serie
Standard voltage
Voltage standard
Serienmäßige Spannung
Voltaje en serie



Sbrinamento manuale
Manual defrosting
Dégivrage manuel
Manuelles Abtauen
Descongelación manual



Sbrinamento automatico
Automatic defrosting
Dégivrage automatique
Automatisches Abtauen
Descongelación automática



Refrigerazione
Refrigeration
Réfrigération
Kühlung
Refrigeración



Refrigerazione statica
Static refrigeration
Réfrigération statique
Statische Kühlung
Refrigeración estática



Refrigerazione ventilata
Ventilated refrigeration
Réfrigération ventilée
Belüftete Kühlung
Refrigeración ventilada



Refrigerazione agitata
Fan assisted refrigeration
Réfrigération troublée
Geschüttelte Kühlung
Refrigeración estática con pseudo-ventilador



Gas refrigerante
Cooling gas
Gaz réfrigérant
Kühlgas
Gas refrigerante



Potenze resistenze Bain-Marie
Bain-Marie heating elements power
Puissance des résistances Bain-Marie
Leistung der wasserbadheizkörper
Potencia resistencias Baño María



Peso netto
Net weight
Poids net
Nettogewicht
Peso neto



Bacinelle
Trays
Cuvettes
Schalen
Bandejas

EUROLINE
VINO
BIRRA
BAR
MERCATI SPECIALI
LABORATORI PASTICCERIA
RISTORAZIONE
FAST FOOD
PIZZERIA
CUCINA
ESPOSIZIONE
SUPERMERCATI
HYPERMARKET