



SAFIRA

SAFIRA



Como uma pedra preciosa que reluz, realçando a sua própria beleza, a Safira foi concebida com uma superfície envidraçada que não só garante maior visibilidade como permite, através da entrada da luz, destacar os produtos expostos.

O sistema de gavetas deslizantes assume-se como uma mais-valia no desempenho diário do móvel, garantindo uma melhor optimização do espaço (reforçada pela existência de duas prateleiras neutras) e rapidez no serviço.

Disponível nas versões refrigerada, padaria e neutra, o novo design da Safira e as diversas soluções decorativas permitem criar novos ambientes onde elegância e sofisticação se assumem como conceitos-chave.

Como una joya que brilla, realzando su propia belleza, la Safira se ha diseñado con una superficie de cristal que garantiza una mayor visibilidad a través de la entrada de luz, lo cual garantiza un mayor destaque de los productos expuestos.

El sistema de plano de exposición deslizante se asume como un activo en el rendimiento diario de mayor movilidad, asegurando una mejor optimización del espacio (reforzada por la existencia de dos estanterías neutras) y la rapidez del servicio.

Disponibile en versiones refrigerada, panadería y neutra, el nuevo diseño de la Safira y las diversas soluciones de decoración permiten crear nuevos ambientes donde la elegancia y la sofisticación se asumen como conceptos fundamentales.

Like a gem that shines and brings out its beauty, Safira was conceived with a surface that allows light in to bring out the products displayed.

The draw system is an added value to help in the day to day performance allowing a better optimization of space (so as the two neutral shelves above) and speedy in serving.

Available in refrigerated, bakery and neutral versions, its new design and decorative solutions allow the creation of new ambiances where elegance and sophistication can be found.

Comme une gemme qui brille, en attirant l'attention sur son propre beauté, la Safira est conçue avec une surface vitrée qui non seulement assure une plus grande visibilité comme permet, grâce à l'entrée de la lumière, de mettre en évidence les produits exposés.

Le système de tiroirs coulissants, s'assume comme une valeur rajoutée dans la performance quotidienne de la vitrine, en assurant une meilleure optimisation de l'espace (renforcée par l'existence de deux étagères neutres) et la rapidité dans le service.

Disponibile dans les versions réfrigérée, boulangerie et neutre, le nouveau design de la Safira et les différentes solutions de décorations permettent créer nouveaux environnements où l'élégance et la sophistication sont des concepts fondamentales.

Wie ein Edelstein das glänzt und seine eigene Schönheit betont, wurde Safira mit einer Glasoberfläche hergestellt welche nicht nur grössere Sichtbarkeit garantiert sondern auch die Betonung der ausgestellten Produkte durch Lichteingang ermöglicht.

Das System von Gleitschubladen ist ein Mehrwert in der täglichen Erfüllung des Möbels und garantiert eine bessere Optimierung des Platzes (durch zwei neutrale Regale verstärkt) und Schnelligkeit im Dienst.

Verfügbar in den Arten Kühlgut, Backwaren und neutral, ermöglichen das neue Design und die verschiedenen Dekorlösungen der Safira, die Hervorbringung einer neuen Atmosphäre, wo Eleganz und Hochentwicklung wichtige Begriffe sind. Safira kann auch mit Mozart's Balkon verbunden sein.

SAFIRA



SAFIRA



Tampas e Rodapés Working Tops and Plinths

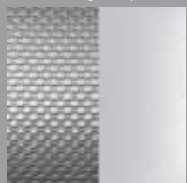

Inox / Stainless Steel



Granito Moca



Granito Preto Nacional



Granito African Red



Mármore / Marble

Decorações Madeira Wooden Decors



Faia

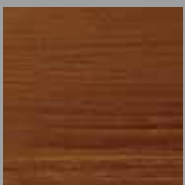

Cerejeira

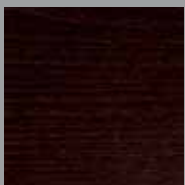

Wengué

Decorações Lacados Lacquered Decors



RAL 1014

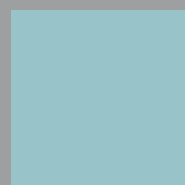

RAL 6027

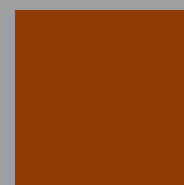

RAL 3009

A reprodução fotográfica das cores é a mais real possível, servindo apenas como orientação. Las reproducciones de colores son tan verdaderas como sea posible; son solamente una referencia.

The reproductions of colours are as real as possible; the aim is to be used only as a reference. La reproduction photographique des couleurs est le plus réel possible, servant seulement pour orientation.

Die Wiedergaben von Farben sind so real, wie möglich; das Ziel ist, nur als Hinweis verwendet zu werden.

SAFIRA

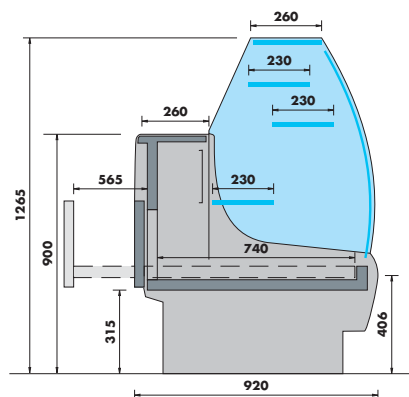

SAFIRA VCR

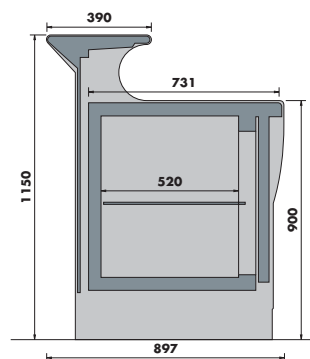

MOZART FV

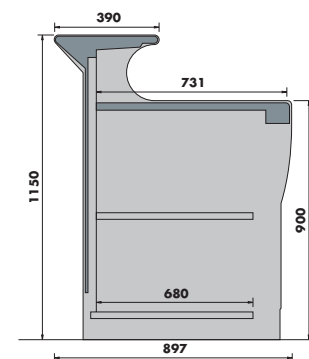

MOZART NEUTRO

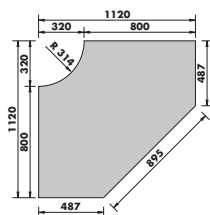

ÂNGULO INTERNO 90° - MESA COMPOSITORES
90° INTERNAL CORNER - COMPOSERS CASH DESK

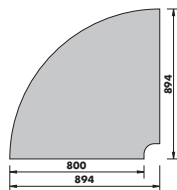

ÂNGULO EXTERNO 90° - MESA COMPOSITORES
90° EXTERNAL CORNER - COMPOSERS CASH DESK

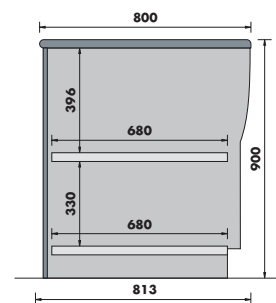

MESA COMPOSITORES
COMPOSERS CASH DESK

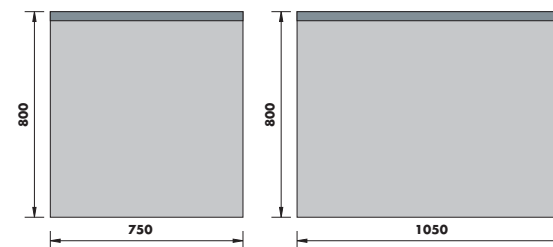

MESAS COMPOSITORES
COMPOSERS CASH DESKS

MODELO MODELO MODEL MODELE MODELL	COMPRIMENTO TOTAL LONGITUD TOTAL TOTAL LENGTH LONGUEUR TOTAL LÄNGE SUMME (mm)	COMPRIMENTO SEM LATERAIS LONGITUD SIN LATERALES LENGTH WITHOUT SIDE PANELS LONGUEUR SANS JOURS LATÉRALES LÄNGE OHNE SEITENWÄNDE (mm)	TEMPERATURA DE FUNCIONAMENTO TEMPERATURA DE FUNCIONAMIENTO WORKING TEMPERATURE TEMPÉRATURE DE FONCTIONNEMENT BETRIEBSTEMPERATUR (°C)	SUPERFÍCIE DE EXPOSIÇÃO REFRIGERADA SUPERFICIE DE EXPOSICIÓN REFRIGERADA REFRIGERATED DISPLAY AREA SURFACE D'ÉTALAGE REFRIGÉRÉE AUSSTELLFLÄCHE (m ²)	NÚMERO DE PORTAS NÚMERO DE PUERTAS NUMBER OF DOORS NOMBRE DE PORTES ANZAHL TÜREN	POTÊNCIA FRIGORÍFICA POTENCIA FRIGORÍFICA REFRIGERATION POWER POTENCE FRIGORIFIQUE KÜHLEISTUNG (W)	PESO LÍQUIDO / BRUTO PEÑO NETO / BRUTO NET / GROSS WEIGHT POIDS NET / BRUT GEWICHT NETTO / BRUTTO (kg)
900	1000	900	+3 / +6	1,29	1	350	160 / 215
1800	1900	1800	+3 / +6	2,57	2	580	260 / 320
2700	2800	2700	+3 / +6	3,89	3	800	360 / 430

CLASSE CLIMÁTICA / CLASE CLIMÁTICA / CLIMATIC CLASS / CLASSE CLIMATIQUE / KLIMAKLASSE: 3 (+25°C / HR 60%) GAS: R404A



MAFIROL

www.mafirol.com

Fábrica/Fábrica/Factory/Usine/Produktion

MAFIROL - Indústria de Refrigeração, SA

Rua Alto do Vale do Grou 956 • 3750-872 Borralha • Águeda • Portugal • Tel: 234 610 400 • Fax: 234 610 401
www.mafirol.com • e-mail:inform@mafirol.com

Serviços Comerciais/Servicios Comerciales/Commercial Services/Services Commerciaux/Vertrieb

Braga: Parque Industrial de Celeirós, lote D4 2ª Fase • 4705-414 Braga • Tel: 253 672 905 • Fax: 253 673 243

Porto: Rua do Outeiro, lote 27 sector 1 - Zona Industrial Maia - Gemunde • 4475-132 Maia • Tel: 229 477 620 • Fax: 229 477 629

Viseu: Estrada Velha de Abraveses - Quinta S. João das Lameiras, lote B r/c • 3510-204 Abraveses • Tel: 232 459 290 • Fax: 232 458 138

Águeda: Rua Alto do Vale do Grou 976 • 3750-872 Borralha • Águeda • Tel: 234 610 480 • Fax: 234 610 481

Leiria: Quinta da Alçada, lote 3 r/c dto • Gândara dos Olivais • 2415-569 Leiria • Tel: 244 828 391 • Fax: 244 828 113

Lisboa: Polígono dos Álamos - Quinta das Areias, lote 41 • 2600-660 Castanheira do Ribatejo • Tel: 263 285 680 • Fax: 263 285 689

Export Department: Tel: +351 234 610 440 • Fax: +351 234 610 441