

ZIEGRA Bruch-Eis Maschine
Typenblatt

ZBE 250

ZIEGRA Chip Ice Machine
Data Sheet

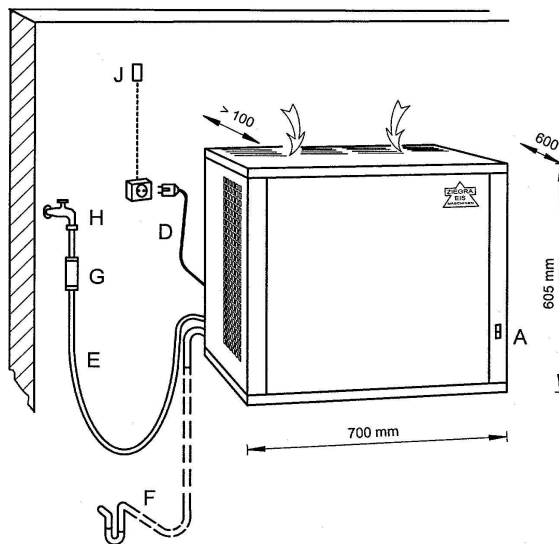
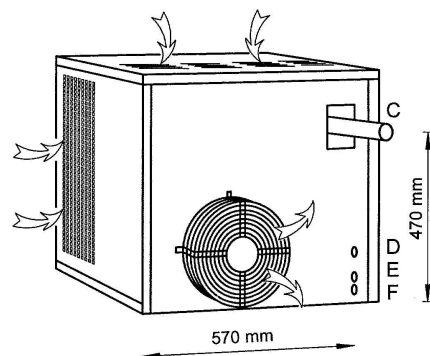

A:	Betriebsschalter			operating switch
C:	Eis-Auswurf			ice hose
D:	Elt.-Kabel/Stecker	230V-1-50 Hz	2 m	electric cable/plug
E:	Wasserzulauf	1-6 bar 3/4"	2 m	water connection
F:	Wasserüberlauf	14 mm ø	2 m	overflow

Bauseits vorsehen:

G:	Schmutzfänger			filter
H:	Absperrhahn			stop valve
J:	Absicherung	16 A träge - slow		fuses
	Kabelquerschnitt	1,5 mm ² Cu		cable cross section

install on site:

Gewicht	80 kg	weight
---------	-------	--------